

Areas of application

- Street and urban lighting
- Industry
- Suitable for outdoor applications in luminaires with IP > 54
- Suitable for use in outdoor luminaires of protection class I and II

Technical data

Electrical data

Max. ECG no. on circuit breaker 10 A (B)	3 ¹⁾
Max. ECG no. on circuit breaker 16 A (B)	5 ¹⁾
Maximum output power	200 W
Minimum output current	70 mA ²⁾
Nominal output current	350...1050 mA ³⁾
Nominal output power	200 W
Nominal output voltage	145...285 V
Nominal input voltage	220...240 V
Input voltage AC	198...264 V
Device power loss	16.5 W ⁴⁾
Efficiency in full-load	92.5 % ⁵⁾
Inrush current	82 A ⁶⁾
Power factor λ	> 0.95 ⁷⁾
Mains frequency	50/60 Hz
Surge capability (L-N)	6 kV ⁸⁾
Surge capability (L/N-Ground)	10 kV
U-OUT (working voltage)	400 V
Output current tolerance	±5 %
Output ripple current (100 Hz)	< ±5 % ⁹⁾
Total harmonic distortion	< 10 % ¹⁰⁾
Default output current	700 mA

1) Type B

2) Physical Minimum Dimming Current

3) Default 700 mA; 200...1050 mA adjustable

4) At Full load, 230 V, 50 Hz

5) at 230 V, 50 Hz

6) Max, $t_h = 298\mu s$

7) Full load at 230 V / 50 Hz

8) @ 2 Ohm, acc. to EN61547

9) Ripple / average @ 100 Hz

10) At full load, 230 V, 50 Hz / see graphs

Typical Power Factor v Load

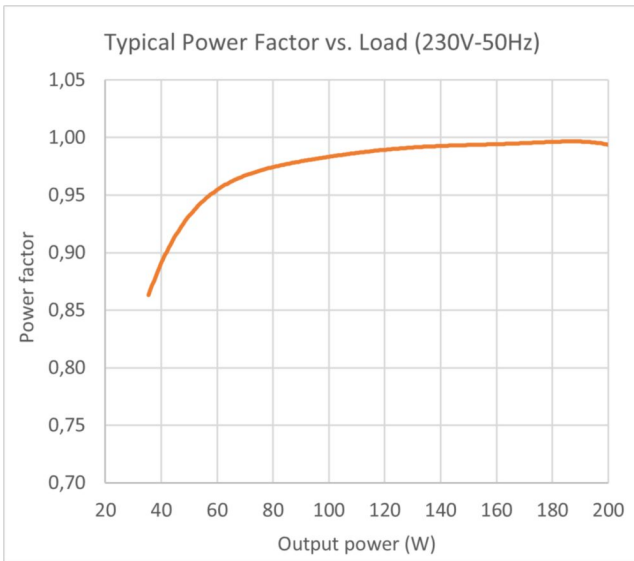

IT DALI 200 120-240 1A0 E Typical Power Factor vs Load 081222

Operating Window

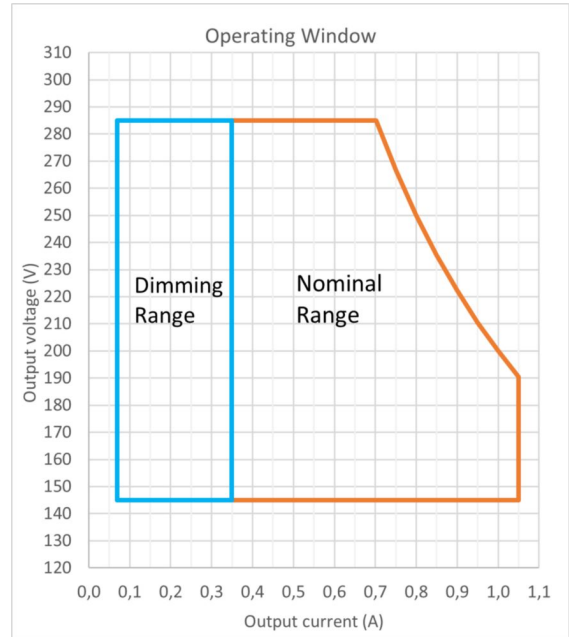

IT DALI 200 120-240 1A0 E Operating Window

Typical THD v Load

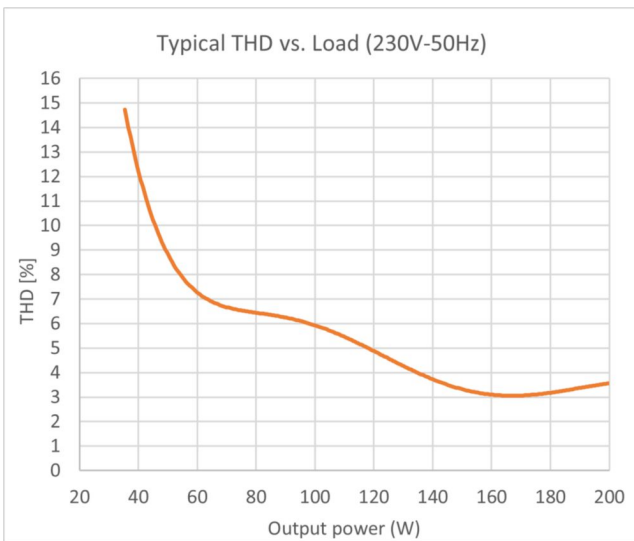

IT DALI 200 120-240 1A0 E Typical THD vs. Load 081222

Typical Efficiency v Load 230 V 50 Hz

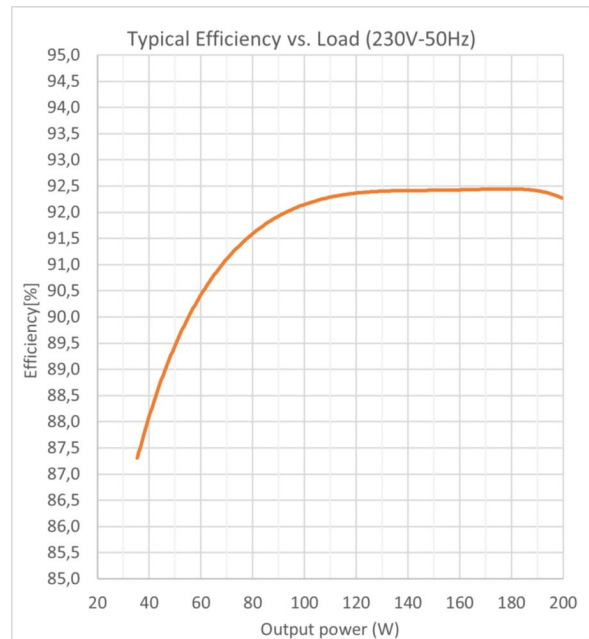

IT DALI 200 120-240 1A0 E Typical Efficiency vs Load

Dimensions & weight

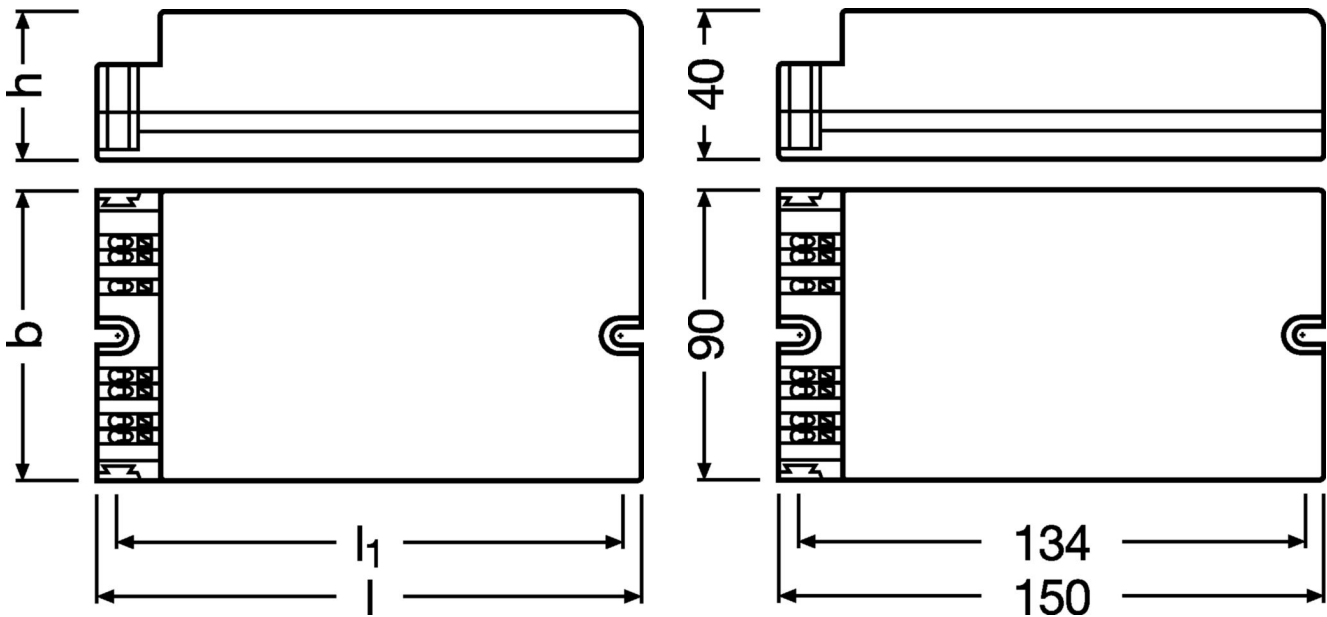

Product weight	780.00 g
Length	170.0 mm
Height	40.0 mm
Width	100.0 mm
Cable cross-section, input side	0.2...1.5 mm ^{2 1)}
Cable cross-section, output side	0.2...1.5 mm ^{2 1)}
Mounting hole spacing, length	160.0 mm
Mounting hole spacing, width	90.0 mm
Wire preparation length, input side	8.5...9.5 mm
Wire preparation length, output side	8.5...9.5 mm

1) Flexible / Solid leads

Colors & materials

Casing material	Plastic
-----------------	---------

Temperatures & operating conditions

Ambient temperature range	-40...+55 °C
Max.housing temperature in case of fault	120 °C
Maximum temperature at tc test point	90 °C ¹⁾
Permitted rel. humidity during operation	5...85 % ²⁾
Temperature range at storage	-25...80 °C

1) Measured on tc point indicated on the product label.

2) Non-condensing

Lifespan

ECG lifetime	50000 h / 100000 h ¹⁾
---------------------	----------------------------------

1) $T_c = 80^\circ\text{C}$, 0.2% / 1,000 h failure rate / $T_c = 70^\circ\text{C}$, 0.1% / 1,000 h failure rate

Capabilities

Max. cable length to lamp/LED module	2.0 m ¹⁾
Number of channels	1
Dimmable	Yes
Dimming interface	AstroDIM / DALI-2
Dimming range	10...100 %
Overload protection	Automatic reversible
Overheating protection	Yes
Short-circuit protection	Yes
Suitable for fixtures with prot. class	I / II
Type of connection, input side	Terminal
Type of connection, output side	Terminal
Constant lumen function	Programmable
LEDset	No
No-load proof	Yes

1) Output wires must be routed as close as possible to each other

Programming

Box programming	No
-----------------	----

Programmable features

AstroDIM	Yes
Configuration Lock	Yes
DALI-2 Luminaire Data	Yes ¹⁾
Driver Guard	No
Emergency Mode	No
MainsDIM	No
StepDIM	No

1) Acc. DALI part 251

Certificates & standards

Type of protection	IP20
Standards	Acc. to EN 61347-1 / Acc. to EN 61347-2-13 / Acc. to EN 55015 / Acc. to EN 61547 / Acc. to EN 61000-3-2 / Acc. to EN 62384 / Acc. to EN 62386
Approval marks – approval	CCC / CE / DALI-2 / EAC / ENEC / RCM / UKCA

Logistical data

Commodity code	85044083900
----------------	-------------

Environmental information

Information according Art. 33 of EU Regulation (EC) 1907/2006 (REACH)	
Date of Declaration	22-07-2024
Primary Article Identifier	4062172286619
Declaration No. in SCIP database	In work
SCIP_STATUS	In work
SCIP_ID	

Wiring Diagram

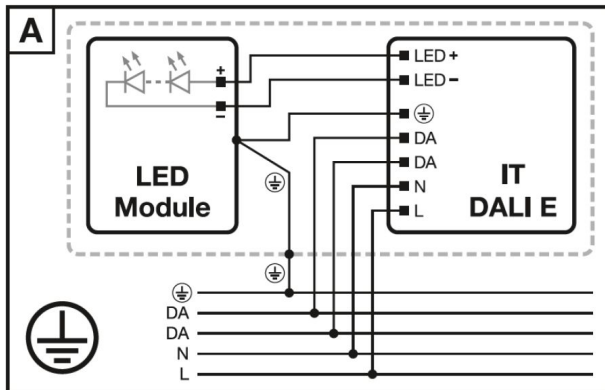

IT DALI 220-240 1A0 E Wiring Diagram

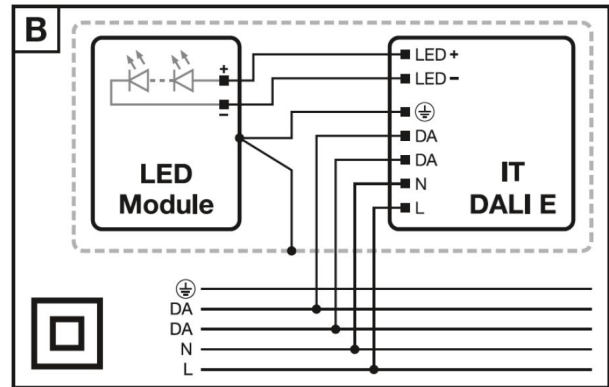

IT DALI 220-240 1A0 E Wiring Diagram

Ecodesign regulation information:

Intended for use with LED modules.

The forward voltage of the LED light source shall be within the defined operating window of the control gear in all operating conditions including dimming if applicable.

Separate control gear and light sources must be disposed of at certified disposal companies in accordance with Directive 2012/19/EU (WEEE) in the EU and with Waste Electrical and Electronic Equipment (WEEE) Regulations 2013 in the UK. For this purpose, collection points for recycling centres and take-back systems (CRSO) are available from retailers or private disposal companies, which accept separate control gear and light sources free of charge. In this way, raw materials are conserved and materials are recycled.

Additional product information

- The driver withstands an input voltage of up to 300 V AC for a maximum of two hours. An output load shutdown can occur in case the supply voltage exceeds the input voltage range defined.
- Shut down of output load happens if the input voltage of the load is below the allowed minimum output voltage of the driver. The driver automatically tries to switch on the load cyclically.
- The driver automatically switches into protection mode when output voltage exceeds limit and return to normal when the fault condition is removed.
- The driver automatically reduces the output current in case the maximum allowed output power is exceeded.
- The driver automatically reduces the output current in case the maximum allowed output power is exceeded, as long as the input voltage of the load is within the declared output voltage range of the driver. In all other cases the driver may shut down the load.
- The driver is protected against temporary overheating by automatically reduction of the output current.
- The EQUI pin shall be connected to the heat sink of the LED module to improve the surge withstand capability of the system and EMI in critical luminaires.
- The constant lumen feature is disabled by default.
- If any output level is below the physical min level, the physical min level will be used.

Download Data

File		
Certificates	PDF	▶IT DALI 200 1A0 E ENEC 35 123254 01 200923
Certificates	PDF	▶OT constant current EAC PA01 B 01618 21 220223
CAD data	Compressed	▶IT DALI 200 1A0 E STEP 300323
Mandatory Publications	PDF	▶IT DALI 200 1A0 E CE 4403323 02 040523
Mandatory Publications	PDF	▶IT DALI 200 1A0 E UK DoC 4403324 01 220923
User instruction	PDF	▶User Instruction

Logistical Data

Product code	Product description	Packaging unit (Pieces/Unit)	Dimensions (length x width x height)	Volume	Gross weight
4062172286619	IT DALI 200/220-240/1A0 E	Shipping carton box 10 Pieces	303 x 285 x 205 mm	17.70 dm ³	827.10 g

The mentioned product code describes the smallest quantity unit which can be ordered. One shipping unit can contain one or more single products. When placing an order, for the quantity please enter single or multiples of a shipping unit

References / Links

* For more information on the multi-level guarantee and the terms and conditions of the guarantee visit <https://www.inventronics-light.com/multilevel-guarantees>

Accessories Optional

Product description	Accessory name	Accessory code
IT DALI 200/220-240/1A0 E	DALI magic	▶ 6977078996907
IT DALI 200/220-240/1A0 E	DALI magic	▶ 6977078997416

Disclaimer

Subject to change without notice. Errors and omission excepted. Always make sure to use the most recent release.